

Microcup[®] Electrophoretic Displays, Grayscale and Color Rendition

Jerry Chung, Jack Hou, Wanheng Wang, Li-Yang Chu, Wei Yao and R.C. Liang
SiPix Imaging Inc., Milpitas, California, USA
408-719-8888; www.sipix.com

Abstract

High grayscale, active matrix and passive matrix Microcup[®] electrophoretic displays (EPDs) have been demonstrated with novel driving schemes utilizing the threshold characteristics and mid-tone stability of Microcup[®] EPDs. More than 16 grayscale levels have been achieved. Novel dual-mode driving schemes and circuit designs have also been developed to achieve high color saturation

Introduction

SiPix Imaging, Inc has recently disclosed revolutionary roll-to-roll EPD manufacturing process based on novel Microcup[®] cells and top-sealing technologies⁽¹⁻⁶⁾. Microcup[®] EPD is ultra thin, ultra light, durable and flexible, and it is manufactured on a continuous plastic web at high speed and low cost. In addition to direct drive EPDs, low-voltage driving, active and passive matrix Microcup[®] EPDs have also been demonstrated for a variety of applications.

A Passive Matrix EPD (PMEPD) driven by traditional column and row electrodes has been generally considered a major technical challenge. The threshold characteristics needed to suppress the undesirable cross-talk effects among non-addressed pixels during multiplexing driving does not exist in most electrophoretic systems. By optimizing the particle-particle, particle-sealing layer, and particle-Microcup[®] interactions, satisfactory threshold characteristics have been demonstrated in Microcup[®] EPDs^(2,4,5). High performance Microcup[®] PMEPPDs have been prepared at high throughput by the SiPix roll-to-roll process using column and row patterned ITO/PET films. Mid-tone stability has also been demonstrated. Pulse width modulation and pulse count modulation were applied to generate more than 8 grayscales on Microcup[®] PMEPPDs^(4,5). Because of the superior stability of mid-tone image of Microcup[®] EPDs, gray scale rendition may be achieved by pulse amplitude, pulse width or pulse count modulation mechanism, or their combinations. Grayscale Microcup[®] AMEPDs also demonstrated the capability of a significantly higher gray scale without the tradeoffs in for examples pixel resolution and manufacturing cost.

A microcapsule type of Color AMEPD has been demonstrated recently by using a color filter, which

greatly reduces the reflectivity. In contrast, a color Microcup[®] EPD comprises well defined and individually isolated Microcups[®] filled with white pigment-containing microparticles in for examples Red, Green, and Blue fluids. For a reflective type of display, to achieve high color saturation, each pixel must be able to show at least black, white and one primary color, such as R, G or B. A Dual-Mode Microcup[®] EPD drives particles in both Up-and-Down and Side-to-Side (in-plane) directions. This novel structure and driving design shows black, white and color states on each pixel, which dramatically improves the EPD color quality.

Microcup[®] EPD Panel Integration

Two types of Microcup[®] EPD films have been manufactured by the SiPix roll-to-roll process: (1) pre-laminated PMEPPD rolls sandwiched between row and column electrodes, and (2) ready-to-laminate EPD rolls sandwiched between a release liner and an electrode film. Both types of EPD rolls may be cut to desired size and formats, followed by a simple stripping process to expose the electrodes. PMEPPD film (Type 1) is fabricated by laminating sealed EPD onto another electrode substrate, such as Cu/PET, Al/PET, Cu/PI and Al/PI film, which comprises rows or columns of electrodes. An active matrix display (AMEPD) is prepared by laminating the as-sealed Microcup[®] film (type 2) onto a commercially available a-Si TFT back plane. A direct drive EPD is prepared by laminating the as-sealed Microcup[®] film (type 2) onto a commercially available PCB back plane (Figure 1). The PCB back plane provides the segment electrodes for the direct drive EPD.

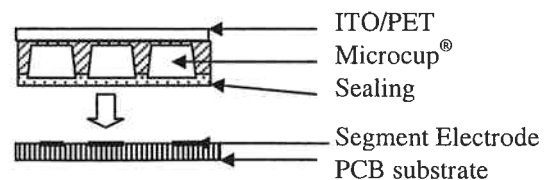

Fig. 1. A direct drive Microcup[®] EPD integrated by direct laminating a sealed EPD film onto a PCB back plane.

In the above 3 types of display, the EPD film is directly laminated to the back plane or the electrode substrate. However, it is advantageous to planarize the back plane or

the electrode substrate before or during lamination (Figure 2). It reduces the surface geometrical differences between the conductor, switching device and the substrate, which improves the lamination quality.

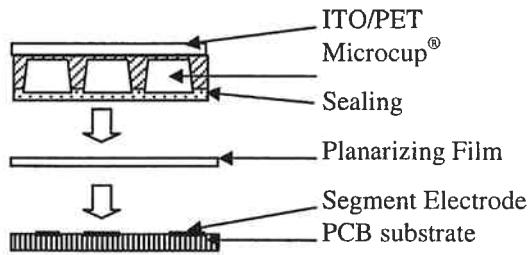

Fig. 2. A direct drive Microcup® EPD integrated by planarizing the back plane PCB before or during lamination.

Grayscale Microcup® Passive Matrix EPD

The driving waveform of a 3x3 passive matrix Microcup® EPD is shown in Figure 3. The panel is first reset to all OFF (black) state, and then selected pixels are driven to ON state row-by-row according to the image data. In this example, the driving voltage to turn on a pixel is set at 30V and the driving threshold of this Microcup® PMPED is 12V. The voltages on the non-addressing rows are set at 10V, the voltages at non-switching columns are set at 20V, and the voltages at the switching columns are set at 0V. In this voltage arrangement, all non-addressed and non-switched pixels are set at either +10V or -10V bias. With 12V driving threshold, the 10V cross-talk bias voltage will not change the state of the pixels.

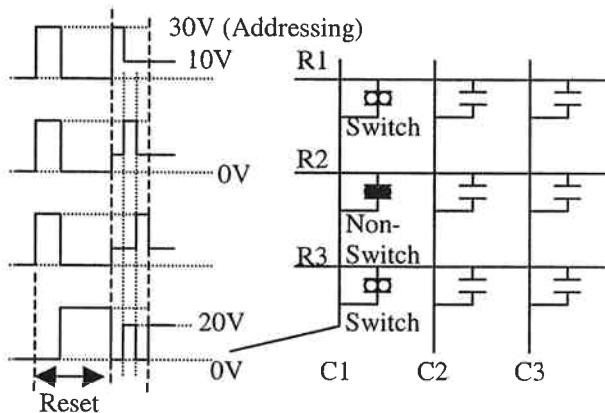

Fig. 3. 3x3 Passive matrix Microcup® EPD driving waveforms with 30V driving voltage and 12V driving threshold.

The grayscale levels are determined by the pulse width ratio of 0V and 20V at the switching columns. A full cycle of 0V drives the pixel to white state, and a 50% 0V 50% 20V pulse drives the pixel to a mid-gray level

(Figure 4). By carefully select the ratio of 0V and 20V pulse width, 8 gray levels have been achieved. Similarly, the voltage amplitude of the switching column can be modulated to show the grayscale of the pixel. Combination of pulse width modulation and pulse amplitude modulation can further optimized to generate more levels of stable grayscale image.

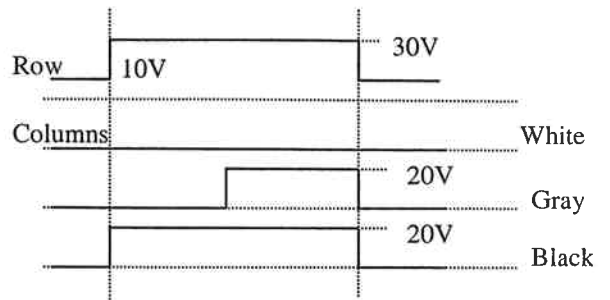

Fig. 4. Passive matrix Microcup® EPD grayscale rendition by pulse width modulation.

Due to the unique structure and surface property of Microcup® as well as the specific surface feature of pigment-containing particles, Microcup® PMPED images with excellent image stability at different grayscale levels are demonstrated. Figure 5 shows a photograph of Microcup® PMPED image containing more than 8 grayscales generated by pulse amplitude modulation, which was taken over 10 days after the power was removed. Measuring the reflectance of each grayscale level at different image retention time, the image stability of each grayscale level of the PMPED was monitored. The percentage of reflectance of the image at each grayscale level remains unchanged for over 10 days, which allows Microcup® PMPED to be used at zero power mode after a high quality grayscale image is displayed.

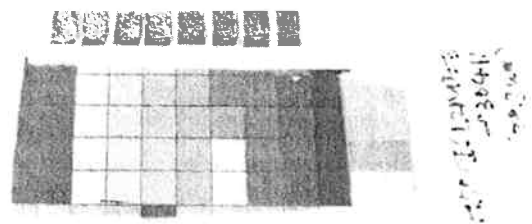

Fig. 5. Grayscale Passive matrix Microcup® EPD with more than 8 gray levels. The photograph was taken 10 days after power was removed.

Grayscale Microcup® Active Matrix EPD

A microcapsule type of Active Matrix EPD (AMEPD) capable of four-level grayscales has been demonstrated recently by an area modulation mechanism⁽⁷⁾ at the expense of pixel resolution. A 4-bit grayscale in-plane EPD with reasonable grayscale bi-stability has also been demonstrated using pulse width and/or amplitude modulation⁽⁸⁾. Because of the mid-tone stability and novel driving scheme, Microcup® AMEPDs are capable of a significantly higher gray scale without the tradeoffs in for examples pixel resolution and manufacturing cost.

Figure 6 illustrates one example of the driving waveforms to address Microcup® AMEPD. The TFT back plane is a commercially available a-Si TFT on glass substrate. The source lines are driven at either 0V or 23V according to the image data, and the common electrode is set at 10V. At this setting, the pixels at the turned-on TFTs are either biased at +10V or -10V. The frame rate is set at 120Hz or about 8.3 ms per cycle. The Ton/Toff of this example is about 500 ms, therefore after 60 scan cycles, all the pixels are driven to the designated states and the image appears. The grayscale image is generated as follow. First, all the pixels are reset to off (black) state by setting all source drivers to 0V followed by the 60 scan cycles which drive the pixels to a specific gray level. For a white pixel, the corresponding source driver is set at 23V in all 60 cycles. For a mid-gray pixel, the source driver is set at 0V in the first 30 cycles and 23V in the second 30 cycles. For a dark pixel, the source driver is set at 0V in all 60 cycles. It's easy to comprehend that voltage amplitude modulation can also be used to generate the grayscale levels. A combination of amplitude modulation and the above drive cycle modulation has the potential to drive more than 16 grayscale levels.

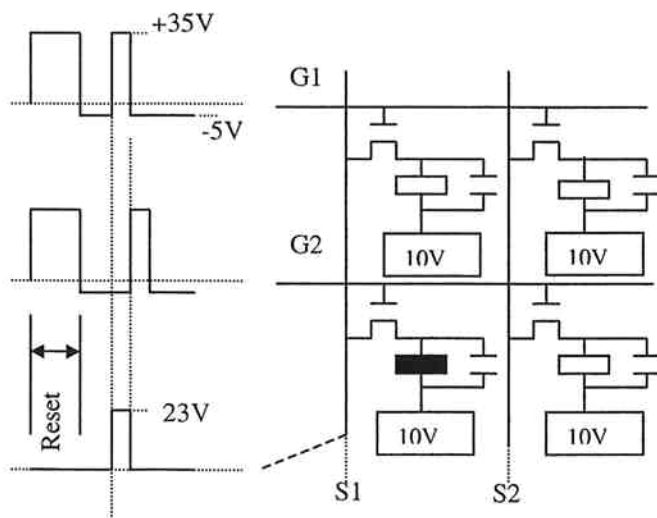

Fig. 6. 2x2 Active matrix Microcup® EPD driving waveforms with +10V/-10V driving voltage.

Color Dual-Mode Microcup® EPD

A Dual-Mode Microcup® EPD (Figure 7) comprises a top electrode, bottom electrode, and side in-plane electrodes. There is also a black back plate under the transparent bottom electrode and transparent in-plane electrodes. It's called Dual-Mode because the particles are driven in both Up-and-Down and Side-to-Side (in-plane) directions. For illustration, in the following scenarios positively charged white particles are dispersed in colored solvent. Figure 8A shows a voltage setting to drive all particles in a Microcup® to the top electrode, and the white particles are perceived as white state. Figure 8B shows a voltage setting to drive all particles in a Microcup® to cover the bottom electrode and the in-plane electrodes. In this case, blue solvent is perceived and the Microcup® is in the Blue state. Figure 8C shows a voltage setting to drive all particles in a Microcup® to the in-plane electrodes at both sides. In this case, black back plate is perceived, and the Microcup® is in the Black state. A computer simulation shows the color saturation achieved by such a Dual Mode Color Microcup® EPD is much better than the EPDs using color filter. Figure 9 shows the color gamut by simulation.

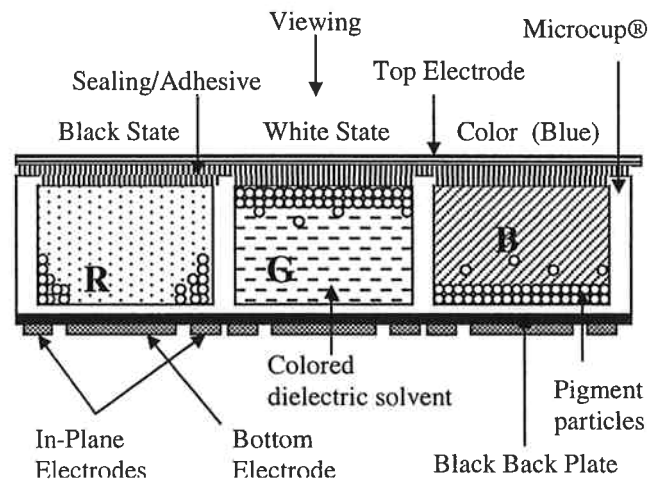

Fig. 7. Dual Mode Microcup® EPD comprises in-plane electrode, top electrode, bottom electrode and black back plate.

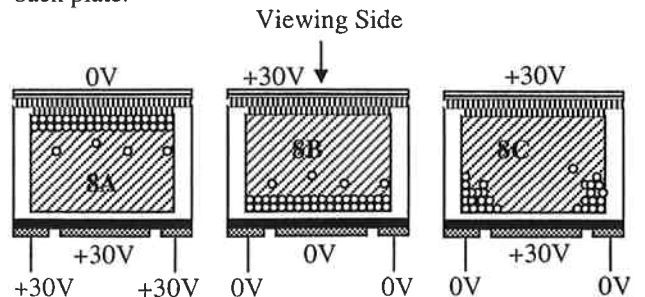

Fig. 8(A)(B)(C). Dual Mode Microcup® EPD Driving voltage settings for white, color and black states .

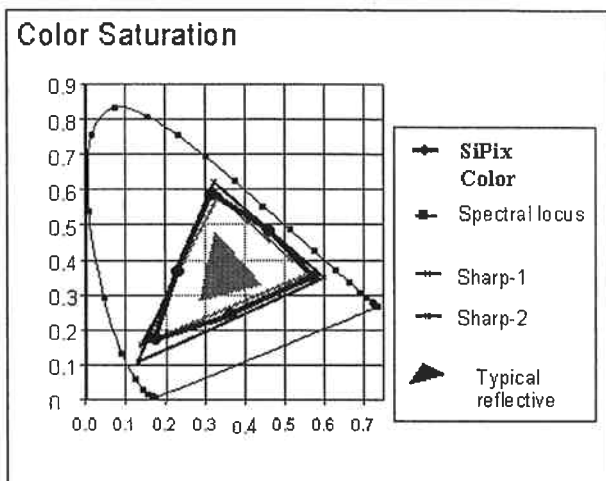

Fig. 9. Color gamut simulation of Color Dual Mode Microcup® EPD.

In many cases, it is desirable to be able to display shades of colors other than just the main colors from each cell. For example, in a dual mode Microcup® EPD in which the main colors are red, white and black, it may be desirable to be able to display intermediate shades of a red color. Figure 10 illustrates the grayscale option with a Dual Mode Color Microcup® EPD. In this scenario, the area coverage by the white particles on the black background affects the “darkness” of the red color. The perception of the level of “redness” or “darkness”, in each cell depends on the ratio of the black area and red area or in other words, the extent in which the white particles cover the black background. This color control scheme is suitable for a RGB system that comprises cells with red, green and blue solvent with white particles dispersed therein.

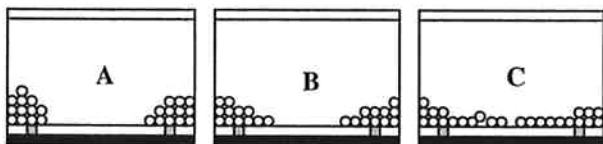

Fig. 10. Color value control of Color Dual Mode Microcup® EPD.

This type of grayscale control can be achieved by first driving all of the white particles to the electrodes as shown in cell A. A specific amount of the white particles are then driven to the bottom electrode according to the desired value of color. The white state is achieved by driving all the white particles to the top to cover the top-viewing surface. The amount of the particles driven to the bottom electrode may be determined by using the grayscale control technique. The grayscale control can be

implemented by driving pulse amplitude modulation or driving pulse width modulation. Another driving method is to apply multiple pulses to the electrodes. More pulses can provide more driving power and move more particles to the bottom electrode. The above three driving methods can be implemented in either passive matrix or active matrix driving, and can also be combined to achieve optimal color grayscale control.

References

1. R.C. Liang, J. Hou, and H.M. Zang; IDW 02' Proceedings, EP2-2, p. 1337, Dec. 2002, Hiroshima, Japan; “Microcup® Electrophoretic Displays by Roll-to-Roll Manufacturing Processes”
2. R.C. Liang, J. Hou, H.M. Zang, and J. Chung; IDMC 03' Proceedings, Fr-17-05, p. 351, Feb. 2003, Taipei, Taiwan; “Passive Matrix Microcup® Electrophoretic Displays”
3. R.C. Liang; USDC Flexible Microelectronics and Display Conferences; Feb. 3-4, 2003, Phoenix, AZ. “Microcup® EPDs and LCDs by Roll-to-Roll Manufacturing Process”.
4. R.C. Liang, J. Hou, J. Chung, X. Wang, C. Pereira, and Y. Chen; SID 03' Digest, paper 20.1, May 2003, Baltimore; “Microcup® Active and Passive Matrix Electrophoretic Displays by Roll-to-Roll Manufacturing Processes”.
5. R.C. Liang, J. Hou, HM Zang, J. Chung and S. Tseng, J. SID, 09/2003 (in Press).
6. H.M. Zang and R.C. Liang, *The Spectrum*, **16**(2), p.16 (2003).
7. S. Inoue, H. Kawai, S. Kanbe, T. Saeki, and T. Shimoda; *IEEE Trans. Electr. Dev.*, 49(8), p.1532 (2002).
8. Y. Matsuda, E. Kishi, T. Goden, A. Ogawa, N. Ukigaya, Y. Uno, K. Ishige, T. Ikeda, and H. Matsuda; IDW '02, EP2-3, December (2002).